



CANADIAN NIAGARA POWER INC.

A FORTIS ONTARIO  
Company

## MicroFIT GENERATION PROGRAM INFORMATION

This information sheet is applicable to Canadian Niagara Power Inc. (“CNPI”) customers wishing to install one or multiple generating units at the Customer’s facility with total nameplate rating of 10 kW or less.

### 1. Getting Started

---

To determine whether your energy generation project is feasible, make sure you are informed about the microFIT program, connection process and required approvals. Here are some important things to know:

#### Benefits of the microFIT Program:

- Get paid for the power you produce
- Contribute to a healthier environment
- Help to create new local businesses and green jobs

#### Make sure that this Program is Right for You:

Your planned generation facility must generate electricity from the following renewable energy sources, and must be smaller than 10 kiloWatts (10 000 Watts) total generation:

- a) solar radiation (photovoltaic or “PV”)
- b) wind
- c) water
- d) agricultural biomass

#### Do your Homework:

- Take advantage of industry associations, government agencies and local retailers to learn as much as you can about energy generation and what is required to make your project a success. Good resources are:
  - a) Ontario Power Authority (OPA)- 1-888-387-3403 or <http://microfit.powerauthority.on.ca/>
  - b) Canadian Solar Industries Association - <http://www.cansia.ca/>
  - c) Canadian Wind Energy Association - <http://www.canwea.ca/>
  - d) Ontario Water Power Association - <http://www.owa.ca/>
  - e) Canadian Bioenergy Association - <http://www.canbio.ca/>
  - f) Electrical Safety Authority – <http://esasafe.com/>
  - g) CNPI – Visit us in person, or call or Customer Service Department at (905) 871-0330. Be sure to mention that you are interested in microFIT generation.
- Make sure that you understand the costs, the technical requirements, the legal requirements, and especially the safety requirements associated with energy generation.
- Proper planning will keep your project on time and on budget.



CANADIAN NIAGARA POWER INC.

A FORTIS ONTARIO  
Company

## MicroFIT GENERATION PROGRAM INFORMATION

### Enlist Experienced Professionals:

- Hiring a qualified electrical contractor will ensure that your generation is installed safely and the technical requirements of your project are met.
- A business professional, such as an accountant, can inform you about the tax implications of becoming a generator. Businesses may be required to charge GST for the energy they produce, and homeowners' property taxes may be affected.
- Professional engineering and consulting may be required for generation projects. These professionals can help you analyze the potential costs, revenues, technical specifications and safety requirements associated with becoming a generator.

### Contact the Ontario Power Authority (OPA) when you are ready to begin:

Rules established by the Province of Ontario for the microFIT program require that you begin the process by registering with OPA, and then applying for and receiving a long-term contract from them. They may be contacted at:

- a) OPA microFIT Call center: 1-888-387-3403
- b) Internet: <http://microfit.powerauthority.on.ca/index.php>
- c) Direct mail: Ontario Power Authority c/o microFIT Program  
Suite 1600, 120 Adelaide Street West  
Toronto ON, M5H 1t1

## 2. Technical and Legal Issues

---

There are a number of financial, technical and legal issues that you need to consider:

- a) You must meet all relevant electrical safety standards, and obtain an inspection and Connection Authorization from the Ontario Electrical Safety Authority (ESA) ([http://esasafe.com/GeneralPublic/sgi\\_002.php?s=24](http://esasafe.com/GeneralPublic/sgi_002.php?s=24)) before you can be connected to the system.
- b) You may have to obtain a municipal building permit if you will be making significant changes to your home or business.
- c) You must apply for a connection from CNPI. This will be discussed in more detail later in this document. The application is subject to negotiation and execution of a definitive agreement. There will be some costs associated with connection of your generation installation.
- d) You must meet the domestic content rules set by the Ontario Government.
- e) CNPI cannot guarantee continuous and uninterrupted electrical supply to any part of its distribution system. Although CNPI will use reasonable diligence to ensure consistent electrical reliability and power quality, occasional outages or abnormal voltages can still occur. CNPI is not responsible for any losses, damages, or injuries incurred by you as a result of such events.



CANADIAN NIAGARA POWER INC.

A FORTIS ONTARIO  
Company

## MicroFIT GENERATION PROGRAM INFORMATION

- f) There are certain events which can occur on CNPI's distribution system that have the potential to damage the generation equipment that you will be installing. These events include such things as lightning strikes near your service or abnormal voltages caused by trees falling on lines. **You are responsible** for ensuring that you have installed appropriate protective equipment to minimize the probability and extent of such damage. It is advisable to ensure that your home insurance will cover the costs of any such mishap.
- g) If your generation equipment should fail or misoperate, it could cause damages to the electrical system in your home, or to CNPI's distribution system. You may be responsible for the costs associated with any necessary repairs and related damages. For this reason it is essential that you do the following:
- ✓ use qualified people to design and install your generation equipment,
  - ✓ ensure that all equipment and the installation meets the relevant standards and complies with all laws,
- and-
- ✓ perform all necessary scheduled inspections and maintenance on your installation as recommended by the manufacturers and required by law.

### Regulatory Requirements:

In general, the requirements include, but are not limited to the following conditions. Failure to meet and maintain these conditions may result in the invalidation of your OPA contract. CNPI may be required to disconnect your generator until you perform appropriate corrections:

- a) Your generation installation must conform to all relevant Provincial regulations and statutes, such as the Ontario Electrical Safety Code and the Distribution System Code. In addition, your installation must conform to CNPI's *Conditions of Service* as approved by the Ontario Energy Board.
- b) Inverter-based generating units must not inject DC greater than 0.5% of the full rated output current at the point of connection of the generating units. The generated harmonic levels must not exceed those given in the CAN/CSA-C61000-3-6 Standards.
- c) In the event of a power outage to or abnormal voltage on CNPI's distribution system, your installation must disconnect from the 'grid' until power has been properly restored. This is to prevent damage to your equipment and ensure that our personnel can safely make any necessary repairs to our system.
- d) You must install an isolation device (switch) satisfying Section 84 of the Ontario Electrical Safety Code and agree to allow CNPI's staff unrestricted access to and operation of this as required for the maintenance and repair of the distribution system.



## MicroFIT GENERATION PROGRAM INFORMATION

### 3. Connection Types

---

Due to Federal regulatory requirements, the generator must be directly connected to the CNPI system through a separate and distinct revenue meter. The use of indirect or series-connected revenue metering is prohibited.

This diagram shows the connection configuration of a directly connected project using a separate connection to the distribution grid. The meter connected to the microFIT project is completely separate from the load customer meter, although they can share a common supply cable from CNPI. Electricity produced from this microFIT project will flow directly into the distribution grid.

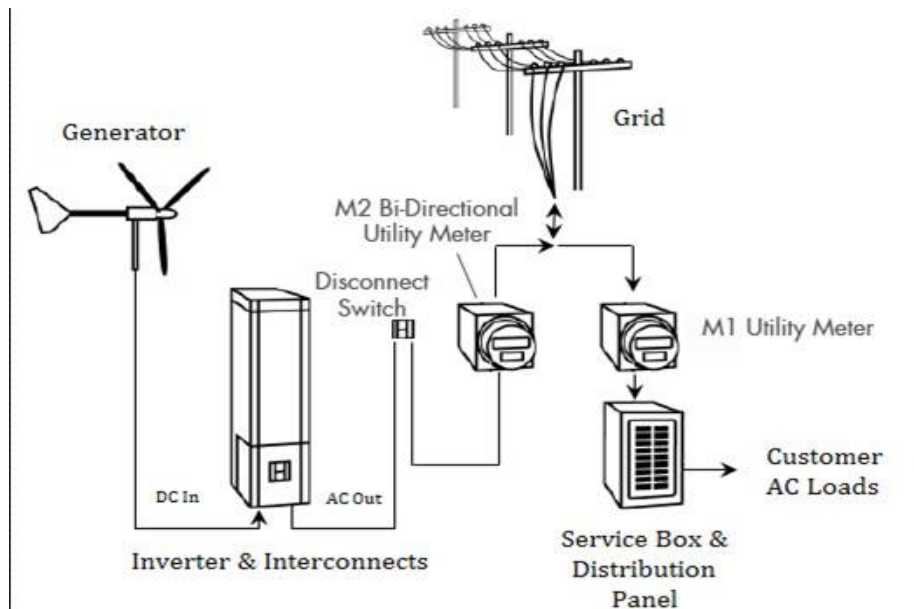

Please note that, in most cases, the existing electrical service supply cable that runs from the property line to the existing 'load' customer meter base will not have to be replaced, if the 'generation' meter base is installed in the same general area on the building.



CANADIAN NIAGARA POWER INC.

A FORTIS ONTARIO  
Company

## MicroFIT GENERATION PROGRAM INFORMATION

### 4. Getting Connected to CNPI's Distribution System

---

#### Sign a contract with the Ontario Power Authority (OPA):

- CNPI cannot proceed with your connection until you have signed a valid contract (complete with project reference number) with the OPA.

#### Get a microFIT Connection Application ("MFCA") from CNPI:

- Once you have a valid signed contract with the OPA, you can proceed to apply for a connection to the CNPI distribution system.
- You can get an Application Form from us in several ways:
  - a) In person, from the Customer Service Department at our office
  - b) From our website at <http://www.cnpower.com/>
  - c) Call our Customer Service department at (905) 871-0330. Be sure to mention that this is a **microFIT application**. We can send a form to you by regular mail, e-mail, or by fax.
- Please ensure that you are working with the most recent version of the MFCA form, as Provincial requirements may change from time to time.

#### Finalize your Generator Design and Return the MFCA form to CNPI:

- CNPI cannot process your MFCA unless all required information is provided, including a valid OPA reference number.
- You are encouraged to refrain from making any significant financial commitments until you conclude all discussions, and enter into a definitive connection agreement with CNPI.
- CNPI will review your application and respond to you within 15 business days.

#### CNPI Review Process:

- The CNPI review process will include, but is not limited to, the following:
  - a) Ensuring that your MFCA is complete,
  - b) Ensuring that our existing distribution system and your customer service equipment is adequate to accommodate your proposed generation installation,
  - c) Meeting with your qualified installer on-site to discuss the following:
    - ✓ Location of the new generation meter base on the outside of your building (usually near your existing 'load' meter base),
    - ✓ Initial costs, payment arrangements, and recurring fees to CNPI as approved by the Ontario Energy Board (OEB),
    - ✓ Identification of any upgrades to CNPI's system that may be required. If they are required, there may be some delays in getting your generator service connected.



CANADIAN NIAGARA POWER INC.

A FORTIS ONTARIO  
Company

## MicroFIT GENERATION PROGRAM INFORMATION

- d) CNPI will prepare and send you an Offer to Connect for your proposed generator installation within 15 business days.

### CNPI Offer to Connect:

- a) Once our review is completed, we will be preparing and sending to you a legally binding document known as an *Offer to Connect*.
- b) This document will outline all the obligations and conditions for both you and CNPI to ensure a safe and reliable installation. These conditions must all be met before the generator can be connected to CNPI's system.
- c) It will describe all costs that you will have to pay to CNPI (as approved by the OEB) prior to connection
- d) You must sign and return this document along with any required payments to CNPI. Note that this will form a legal contract between you and CNPI.

### The Actual Connection:

- a) Once CNPI receives all of the following, we will schedule a commissioning appointment with you within 5 business days (or such later date that you and CNPI agree upon):
  - ✓ Your signed Offer to Connect,
  - ✓ Any payments as required,
  - ✓ A Connection Authorization from ESA.
- b) CNPI will perform an on-site assessment of your installation to ensure that your finished installation matches the information you provided to us in your MFCA.
- c) CNPI will work with your qualified installer to perform certain tests to ensure safe and proper operation of your generator when connected to our system.
  - ✓ Applicants are cautioned that they are **NOT permitted** to interconnect any new generation to CNPI's distribution system without CNPI's express permission **under any circumstances.**
- d) CNPI will then complete your connection.
- e) Upon acceptance by CNPI of your documentation and payment, and satisfactory completion of the on-site commissioning, a legally binding agreement is entered into between you and CNPI.